



Carbamazepine Extended-Release Tablets

Type of Posting	Notice of Intent to Revise
Posting Date	29-Mar-2024
Targeted Official Date	To Be Determined, Revision Bulletin
Expert Committee	Small Molecules 4

In accordance with the Rules and Procedures of the Council of Experts and the [Pending Monograph Guideline](#), this is to provide notice that the Small Molecules 4 Expert Committee intends to revise the Carbamazepine Extended-Release Tablets monograph.

Based on the supporting data received from a manufacturer awaiting FDA approval, the Expert Committee proposes to revise the Carbamazepine Extended-Release Tablets monograph to add *Dissolution Test 9*.

The proposed revision is contingent on FDA approval of a product that meets the proposed monograph specifications. The proposed revision will be published as a Revision Bulletin and an official date will be assigned to coincide as closely as possible with the FDA approval of the associated product.

See below for additional information about the proposed text.¹

Should you have any questions, please contact Yanyin Yang, Senior Scientist II (301-692-3623 or yanyin.yang@usp.org).

¹ This text is not the official version of a *USP–NF* monograph and may not reflect the full and accurate contents of the currently official monograph. Please refer to the current edition of the *USP–NF* for official text.

USP provides this text to indicate changes that we anticipate will be made official once the product subject to this proposed revision under the Pending Monograph Program receives FDA approval. Once FDA approval is granted for the associated revision request, a Revision Bulletin will be posted that will include the changes indicated herein, as well as any changes indicated in the product's final approval, combined with the text of the monograph as effective on the date of approval. Any revisions made to a monograph under the Pending Monograph Program that are posted without prior publication for comment in the *Pharmacopeial Forum* must also meet the requirements outlined in the [USP Guideline on Use of Accelerated Processes for Revisions to the USP–NF](#).

Carbamazepine Extended-Release Tablets

DEFINITION

Carbamazepine Extended-Release Tablets contain NLT 90.0% and NMT 110.0% of the labeled amount of carbamazepine (C₁₅H₁₂N₂O).

IDENTIFICATION

- **A. [SPECTROSCOPIC IDENTIFICATION TESTS](#) (197), [Ultraviolet-Visible Spectroscopy](#): 197U**

Standard solution: 10 µg/mL of [USP Carbamazepine RS](#) in [methanol](#)

Sample solution: Finely powder 1 Tablet, and quantitatively transfer the powder, with the aid of [methanol](#), to a 100-mL volumetric flask. Add about 70 mL of [methanol](#), and shake by mechanical means for 60 min. Sonicate for 15 min, and dilute with [methanol](#) to volume. Allow to stand for 10–15 min. Dilute a portion of the clear solution with [methanol](#) to obtain a solution containing about 10 µg/mL of carbamazepine.

Acceptance criteria: Meet the requirements

- **B.** The retention time of the major peak of the *Sample solution* corresponds to that of the *Standard solution*, as obtained in the *Assay*.

ASSAY

• PROCEDURE

Mobile phase: [Methanol](#), [methylene chloride](#), and [water](#) (450:45:600)

Internal standard solution: 600 µg/mL of phenytoin in [methanol](#)

Standard stock solution: 200 µg/mL of [USP Carbamazepine RS](#) in [methanol](#)

Standard solution: 100 µg/mL of carbamazepine from *Standard stock solution* in *Internal standard solution*

System suitability solution: 50 µg/mL of carbamazepine from *Standard solution* in *Internal standard solution*

Sample stock solution A: Nominally 4 mg/mL of carbamazepine from finely powdered Tablets prepared as follows. Finely powder 10 Tablets. Transfer the powder to an appropriate volumetric flask with the aid of [methanol](#). Add 70% of the flask volume of [methanol](#). Shake by mechanical means for 60 min. Sonicate for 15 min, and dilute with [methanol](#) to volume. Allow to stand for 10–15 min, and then filter a portion of the supernatant. Use the clear filtrate.

Sample stock solution B: Nominally 0.2 mg/mL of carbamazepine from *Sample stock solution A* in [methanol](#)

Sample solution: Nominally 100 µg/mL of carbamazepine from *Sample stock solution B* in *Internal standard solution*

Chromatographic system

(See [Chromatography](#) (621), [System Suitability](#).)

Mode: LC

Detector: UV 230 nm

Columns

Guard: 4.6-mm × 30-mm; 7-μm packing [L7](#)

Analytical: 3.9-mm × 30-cm; packing [L1](#)

Flow rate: 2 mL/min

Injection volume: 10 μL

System suitability

Sample: *System suitability solution*

[NOTE—The relative retention times for phenytoin and carbamazepine are about 0.8 and 1.0, respectively.]

Suitability requirements

Resolution: NLT 2.8 between phenytoin and carbamazepine

Relative standard deviation: NMT 2.0%

Analysis

Samples: *Standard solution* and *Sample solution*

Calculate the percentage of the labeled amount of carbamazepine (C₁₅H₁₂N₂O) in the portion of Tablets taken:

$$\text{Result} = (R_U/R_S) \times (C_S/C_U) \times 100$$

R_U = peak response ratio of carbamazepine to the internal standard from the *Sample solution*

R_S = peak response ratio of carbamazepine to the internal standard from the *Standard solution*

C_S = concentration of [USP Carbamazepine RS](#) in the *Standard solution* (μg/mL)

C_U = nominal concentration of carbamazepine in the *Sample solution* (μg/mL)

Acceptance criteria: 90.0%–110.0%

PERFORMANCE TESTS

Change to read:

- **[DISSOLUTION](#)** <711>

Test 1

Medium

For Tablets labeled to contain 100 mg or 200 mg: [Water](#); 900 mL

For Tablets labeled to contain 400 mg: [Water](#); 1800 mL

Apparatus 1: 100 rpm

Times: 3, 6, 12, and 24 h

Standard solution: [USP Carbamazepine RS](#) in *Medium*

Sample solution: Filtered portions of the solution under test, diluted with *Medium* if necessary

Instrumental conditions

Mode: UV

Analytical wavelength: The wavelength of maximum absorbance at about 284 nm

Analysis

Samples: *Standard solution* and *Sample solution*

Determine the percentage of the labeled amount of carbamazepine (C₁₅H₁₂N₂O) dissolved at each time using the UV absorption.

Tolerances: See [Table 1](#).

Table 1

Time (h)	Amount Dissolved
3	10%–35%
6	35%–65%
12	65%–90%
24	NLT 75%

The percentages of the labeled amount of carbamazepine ($C_{15}H_{12}N_2O$) dissolved at the times specified conform to [Dissolution \(711\)](#), [Acceptance Table 2](#).

Test 2: If the product complies with this test, the labeling indicates that it meets USP *Dissolution Test 2*.

Medium

For Tablets labeled to contain 100 or 200 mg: [Water](#); 900 mL

For Tablets labeled to contain 400 mg: [Water](#); 1800 mL

Apparatus 2: 100 rpm, with sinkers

Times: 2, 4, 12, and 24 h

Standard stock solution: 0.55 mg/mL of [USP Carbamazepine RS](#) in [methanol](#). Sonication may be used to promote dissolution.

Standard solution: 0.0088 mg/mL of [USP Carbamazepine RS](#) from *Standard stock solution* in *Medium*

Sample stock solution: Pass a portion of the solution under test through a suitable filter of 0.45- μ m pore size. Discard the first 3 mL of the filtrate. Replace the portion removed from the solution under test with the same volume of *Medium*.

Sample solution

For Tablets labeled to contain 100 mg: Transfer 2.0 mL of *Sample stock solution* to a 25-mL volumetric flask and dilute with *Medium* to volume.

For Tablets labeled to contain 200 or 400 mg: Transfer 2.0 mL of *Sample stock solution* to a 50-mL volumetric flask and dilute with *Medium* to volume.

Instrumental conditions

(See [Ultraviolet-Visible Spectroscopy \(857\)](#).)

Mode: UV

Analytical wavelength: 284 nm

Analysis

Samples: *Standard solution* and *Sample solution*

Calculate the concentration (C_i) of carbamazepine ($C_{15}H_{12}N_2O$) in the sample withdrawn from the vessel at each time point (i):

$$\text{Result}_i = (A_U/A_S) \times C_S \times D$$

A_U = absorbance from the *Sample solution* at time point i

A_S = absorbance from the *Standard solution*

C_S = concentration of [USP Carbamazepine RS](#) in the *Standard solution* (mg/mL)

D = dilution factor for the *Sample solution*

Calculate the percentage of the labeled amount of carbamazepine ($C_{15}H_{12}N_2O$) dissolved at each time point (i):

$$\text{Result}_1 = C_1 \times V \times (1/L) \times 100$$

$$\text{Result}_2 = [(C_2 \times V) + (C_1 \times V_S)] \times (1/L) \times 100$$

$$\text{Result}_3 = \{(C_3 \times V) + [(C_1 + C_2) \times V_S]\} \times (1/L) \times 100$$

$$\text{Result}_4 = \{(C_4 \times V) + [(C_1 + C_2 + C_3) \times V_S]\} \times (1/L) \times 100$$

C_i = concentration of carbamazepine in the portion of the sample withdrawn at time point i (mg/mL)

V = volume of *Medium*, 900 or 1800 mL

L = label claim (mg/Tablet)

V_S = volume of the *Sample solution* withdrawn at each time point and replaced with *Medium* (mL)

Tolerances: See [Table 2](#).

Table 2

Time Point (i)	Time (h)	Amount Dissolved (for Tablets that contain 100 mg of carbamazepine) (%)	Amount Dissolved (for Tablets that contain 200 or 400 mg of carbamazepine) (%)
1	2	10–30	10–30
2	4	42–62	35–55
3	12	68–88	68–88
4	24	NLT 70	NLT 70

The percentages of the labeled amount of carbamazepine ($C_{15}H_{12}N_2O$) dissolved at the times specified conform to [Dissolution \(711\)](#), [Acceptance Table 2](#).

Test 3: If the product complies with this test, the labeling indicates that it meets USP *Dissolution Test 3*.

Medium: 5 g/L of [sodium dodecyl sulfate](#) in [water](#); 900 mL, deaerated if necessary

Apparatus 1: 100 rpm, with a fixture made of 316 stainless steel to prevent the Tablets from turning during the test (see [Figure 1](#)).

For Tablets with a release hole, orient the hole facing downward in the basket.

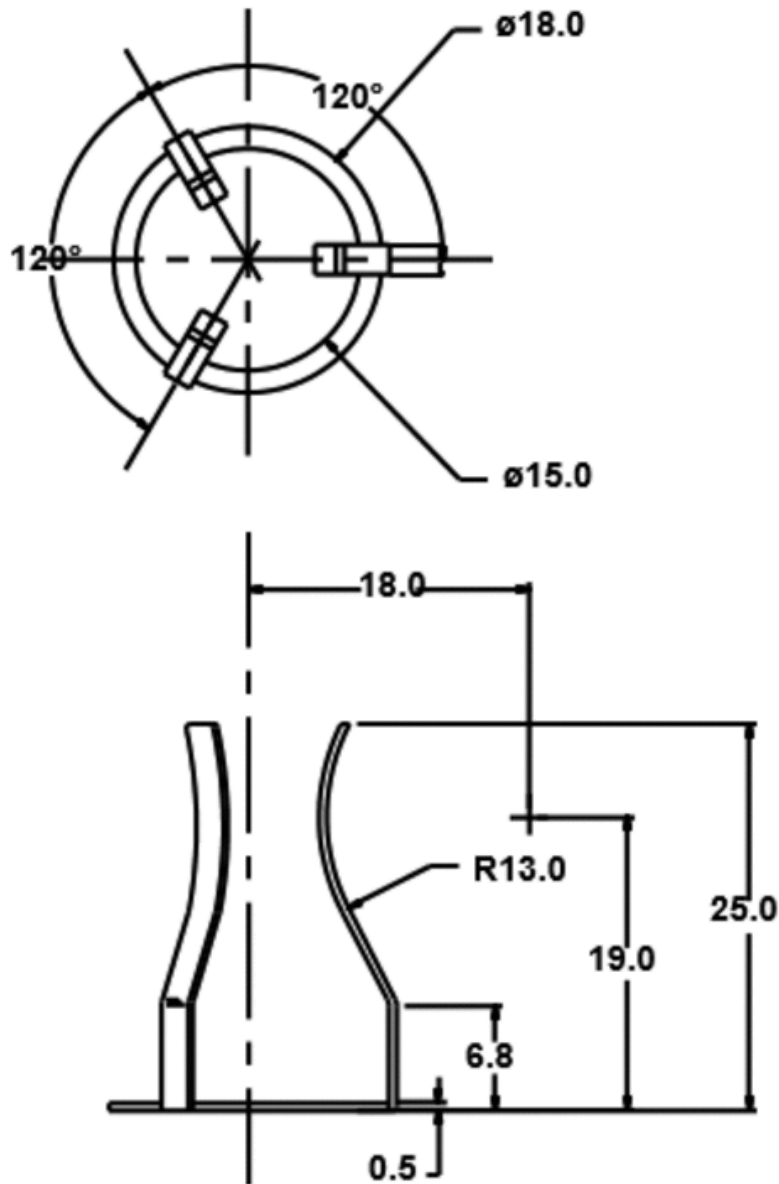

Click image to enlarge

Figure 1. Fixture. All length units are in millimeters.

Times: 3, 6, 12, and 24 h

Standard stock solution: 0.22 mg/mL of [USP Carbamazepine RS](#) prepared as follows. Weigh a suitable amount of [USP Carbamazepine RS](#) in a suitable volumetric flask. Add [methanol](#) to 10% of the flask volume and shake for 10 min to dissolve. Dilute with [water](#) to volume.

Standard solution: 0.0088 mg/mL of [USP Carbamazepine RS](#) from *Standard stock solution* in *Medium*

Sample solution: At the specified time points, withdraw a suitable volume of the solution under test. Pass through a suitable filter of 0.45- μm pore size, discarding an appropriate volume of filtrate so

that a consistent result can be obtained. Dilute with *Medium* to a concentration similar to that of the *Standard solution*.

Instrumental conditions

(See [Ultraviolet-Visible Spectroscopy \(857\)](#).)

Mode: UV

Analytical wavelength: 284 nm

Blank: *Medium*

Analysis

Samples: *Standard solution* and *Sample solution*

Calculate the concentration (C_i) of carbamazepine ($C_{15}H_{12}N_2O$) in the sample withdrawn from the vessel at each time point (i):

$$\text{Result}_i = (A_U/A_S) \times C_S \times D$$

A_U = absorbance from the *Sample solution* at time point i

A_S = absorbance from the *Standard solution*

C_S = concentration of [USP Carbamazepine RS](#) in the *Standard solution* (mg/mL)

D = dilution factor for the *Sample solution*

Calculate the percentage of the labeled amount of carbamazepine ($C_{15}H_{12}N_2O$) dissolved at each time point (i):

$$\text{Result}_1 = C_1 \times V \times (1/L) \times 100$$

$$\text{Result}_2 = \{[C_2 \times (V - V_S)] + (C_1 \times V_S)\} \times (1/L) \times 100$$

$$\text{Result}_3 = \{C_3 \times [V - (2 \times V_S)]\} + [(C_2 + C_1) \times V_S] \times (1/L) \times 100$$

$$\text{Result}_4 = \{C_4 \times [V - (3 \times V_S)]\} + [(C_3 + C_2 + C_1) \times V_S] \times (1/L) \times 100$$

C_i = concentration of carbamazepine in the portion of the sample withdrawn at time point i (mg/mL)

V = volume of the *Medium*, 900 mL

L = label claim (mg/Tablet)

V_S = volume of the *Sample solution* withdrawn at each time point from the *Medium* (mL)

Tolerances: See [Table 3](#).

Table 3

Time Point (i)	Time (h)	Amount Dissolved (%)
1	3	15–40
2	6	42–67
3	12	65–85
4	24	NLT 75

The percentages of the labeled amount of carbamazepine ($C_{15}H_{12}N_2O$) dissolved at the times specified conform to [Dissolution \(711\)](#), [Acceptance Table 2](#).

Test 4: If the product complies with this test, the labeling indicates that it meets USP *Dissolution Test 4*.

Medium

For Tablets labeled to contain 100 or 200 mg: [Water](#); 900 mL

For Tablets labeled to contain 400 mg: [Water](#); 1800 mL

Apparatus 1: 100 rpm

For Tablets with a release hole, orient the hole facing downward in the basket.

Times: 3, 6, 12, and 24 h

Standard stock solution: 0.22 mg/mL of [USP Carbamazepine RS](#) prepared as follows. Transfer a suitable amount of [USP Carbamazepine RS](#) to a suitable volumetric flask. Add [methanol](#) to 5% of the flask volume. Sonicate to dissolve. Dilute with *Medium* to volume.

Standard solution: 0.011 mg/mL of [USP Carbamazepine RS](#) from *Standard stock solution* in *Medium*

Sample stock solution: At the specified time points, withdraw a suitable volume of the solution under test. Pass through a suitable filter of 0.45- μ m pore size, discarding an appropriate volume of filtrate so that a consistent result can be obtained. Replace the portion removed from the solution under test with the same volume of *Medium*.

Sample solution

For Tablets labeled to contain 100 mg: Dilute 5 mL of *Sample stock solution* to 50 mL with *Medium*.

For Tablets labeled to contain 200 or 400 mg: Dilute 5 mL of *Sample stock solution* to 100 mL with *Medium*.

Instrumental conditions

(See [Ultraviolet-Visible Spectroscopy \(857\)](#).)

Mode: UV

Analytical wavelength: 284 nm

Blank: *Medium*

Analysis

Samples: *Standard solution* and *Sample solution*

Calculate the concentration (C_i) of carbamazepine ($C_{15}H_{12}N_2O$) in the sample withdrawn from the vessel at each time point (i):

$$\text{Result}_i = (A_U/A_S) \times C_S \times D$$

A_U = absorbance from the *Sample solution* at time point i

A_S = absorbance from the *Standard solution*

C_S = concentration of [USP Carbamazepine RS](#) in the *Standard solution* (mg/mL)

D = dilution factor for the *Sample solution*

Calculate the percentage of the labeled amount of carbamazepine ($C_{15}H_{12}N_2O$) dissolved at each time point (i):

$$\text{Result}_1 = C_1 \times V \times (1/L) \times 100$$

$$\text{Result}_2 = [(C_2 \times V) + (C_1 \times V_S)] \times (1/L) \times 100$$

$$\text{Result}_3 = \{(C_3 \times V) + [(C_2 + C_1) \times V_S]\} \times (1/L) \times 100$$

$$\text{Result}_4 = \{(C_4 \times V) + [(C_3 + C_2 + C_1) \times V_S]\} \times (1/L) \times 100$$

C_i = concentration of carbamazepine in the portion of the sample withdrawn at time point i (mg/mL)

V = volume of *Medium*, 900 or 1800 mL

L = label claim (mg/Tablet)

V_S = volume of the *Sample solution* withdrawn at each time point and replaced with *Medium* (mL)

Tolerances: See [Table 4](#).

Table 4

Time Point (<i>i</i>)	Time (h)	Amount Dissolved (for Tablets that contain 100 or 200 mg of carbamazepine) (%)	Amount Dissolved (for Tablets that contain 400 mg of carbamazepine) (%)
1	3	10–30	13–33
2	6	40–60	42–62
3	12	65–85	68–88
4	24	NLT 80	NLT 80

The percentages of the labeled amount of carbamazepine ($C_{15}H_{12}N_2O$) dissolved at the times specified conform to [Dissolution \(711\)](#), [Acceptance Table 2](#).

Test 5: If the product complies with this test, the labeling indicates that it meets USP *Dissolution Test 5*.

Medium

For Tablets labeled to contain 100 or 200 mg: [Water](#); 900 mL, deaerated

For Tablets labeled to contain 400 mg: [Water](#); 1800 mL, deaerated

Apparatus 1: 10-mesh basket, 100 rpm

Use a suitable sinker¹ for Tablets labeled to contain 100 or 200 mg. For Tablets with a release hole, orient the hole facing downward in the basket.

Times: 3, 6, 12, and 24 h

Standard solution

For Tablets labeled to contain 100 mg: 0.11 mg/mL of [USP Carbamazepine RS](#) prepared as follows. Transfer a suitable amount of [USP Carbamazepine RS](#) to a suitable volumetric flask. Add [methanol](#) to 2.5% of the flask volume. Sonicate to dissolve. Dilute with *Medium* to volume.

For Tablets labeled to contain 200 or 400 mg: 0.22 mg/mL of [USP Carbamazepine RS](#) prepared as follows. Transfer a suitable amount of [USP Carbamazepine RS](#) to a suitable volumetric flask. Add [methanol](#) to 5% of the flask volume. Sonicate to dissolve. Dilute with *Medium* to volume.

Sample solution: At the specified time points, withdraw a suitable volume of the solution under test. Pass through a suitable filter of 0.45- μ m pore size, discarding an appropriate volume of filtrate so that a consistent result can be obtained.

Instrumental conditions

(See [Ultraviolet-Visible Spectroscopy](#) (857).)

Mode: UV

Analytical wavelength: 284 nm

Cell

For Tablets labeled to contain 100 mg: 0.2 cm

For Tablets labeled to contain 200 or 400 mg: 0.1 cm

Blank: *Medium*

Analysis

Samples: *Standard solution* and *Sample solution*

Calculate the concentration (C_i) of carbamazepine ($C_{15}H_{12}N_2O$) in the sample withdrawn from the vessel at each time point (i):

$$\text{Result}_i = (A_U/A_S) \times C_S$$

A_U = absorbance from the *Sample solution* at time point i

A_S = absorbance from the *Standard solution*

C_S = concentration of [USP Carbamazepine RS](#) in the *Standard solution* (mg/mL)

Calculate the percentage of the labeled amount of carbamazepine ($C_{15}H_{12}N_2O$) dissolved at each time point (i):

$$\text{Result}_1 = C_1 \times V \times (1/L) \times 100$$

$$\text{Result}_2 = \{[C_2 \times (V - V_S)] + (C_1 \times V_S)\} \times (1/L) \times 100$$

$$\text{Result}_3 = (\{C_3 \times [V - (2 \times V_S)]\} + [(C_2 + C_1) \times V_S]) \times (1/L) \times 100$$

$$\text{Result}_4 = (\{C_4 \times [V - (3 \times V_S)]\} + [(C_3 + C_2 + C_1) \times V_S]) \times (1/L) \times 100$$

C_i = concentration of carbamazepine in the portion of the sample withdrawn at time point i (mg/mL)

V = volume of *Medium*, 900 or 1800 mL

L = label claim (mg/Tablet)

V_S = volume of the *Sample solution* withdrawn at each time point from the *Medium* (mL)

Tolerances: See [Table 5](#).

Table 5

Time Point (i)	Time (h)	Amount Dissolved (%)
1	3	18–38
2	6	46–66
3	12	70–90
4	24	NLT 80

The percentages of the labeled amount of carbamazepine ($C_{15}H_{12}N_2O$) dissolved at the times specified conform to [Dissolution \(711\)](#), [Acceptance Table 2](#).

Test 6: If the product complies with this test, the labeling indicates that it meets USP *Dissolution Test 6*.

Medium

For Tablets labeled to contain 100 or 200 mg: [Water](#); 900 mL, deaerated

For Tablets labeled to contain 400 mg: [Water](#); 1800 mL, deaerated

Apparatus 2: 75 rpm

Times: 1, 3, 8, and 24 h

Solution A: Dilute 0.1 mL of [phosphoric acid](#) with [water](#) to 10 mL

Solution B: 1000 mL of [water](#). Adjust with *Solution A* to a pH of 3.5.

Mobile phase: [Methanol](#) and *Solution B* (80:20)

Standard stock solution: 0.22 mg/mL of [USP Carbamazepine RS](#) prepared as follows. Transfer a suitable amount of [USP Carbamazepine RS](#) to a suitable volumetric flask. Add [methanol](#) to 5% of the flask volume. Sonicate to dissolve. Dilute with *Medium* to volume.

Standard solution

For Tablets labeled to contain 100 mg: 0.11 mg/mL of [USP Carbamazepine RS](#) from the *Standard stock solution* in *Medium*

For Tablets labeled to contain 200 or 400 mg: 0.22 mg/mL of [USP Carbamazepine RS](#) from the *Standard stock solution* without dilution

Sample solution: At the specified time points, withdraw a suitable volume of the solution under test. Pass through a suitable filter of 0.45- μ m pore size, discarding an appropriate volume of filtrate so that a consistent result can be obtained. Replace the portion removed from the solution under test with the same volume of *Medium*.

Chromatographic system

(See [Chromatography \(621\)](#), [System Suitability](#).)

Mode: LC

Detector: UV 285 nm

Column: 4.6-mm \times 15-cm; 5- μ m packing [L1](#)

Flow rate: 1 mL/min

Injection volume: 5 μ L

Run time: NLT 2 times the retention time of carbamazepine

System suitability

Sample: *Standard solution*

Suitability requirements

Relative standard deviation: NMT 2.0%

Analysis

Samples: *Standard solution* and *Sample solution*

Calculate the concentration (C_i) of carbamazepine ($C_{15}H_{12}N_2O$) in the sample withdrawn from the vessel at each time point (i):

$$\text{Result}_i = (r_U/r_S) \times C_S$$

r_U = peak response of carbamazepine from the *Sample solution*

r_S = peak response of carbamazepine from the *Standard solution*

C_S = concentration of [USP Carbamazepine RS](#) in the *Standard solution* (mg/mL)

Calculate the percentage of the labeled amount of carbamazepine ($C_{15}H_{12}N_2O$) dissolved at each time point (i):

$$\text{Result}_1 = C_1 \times V \times (1/L) \times 100$$

$$\text{Result}_2 = [(C_2 \times V) + (C_1 \times V_S)] \times (1/L) \times 100$$

$$\text{Result}_3 = \{(C_3 \times V) + [(C_2 + C_1) \times V_S]\} \times (1/L) \times 100$$

$$\text{Result}_4 = \{(C_4 \times V) + [(C_3 + C_2 + C_1) \times V_S]\} \times (1/L) \times 100$$

C_i = concentration of carbamazepine in the portion of the sample withdrawn at time point i (mg/mL)

V = volume of *Medium*, 900 or 1800 mL

L = label claim (mg/Tablet)

V_S = volume of the *Sample solution* withdrawn at each time point and replaced with *Medium* (mL)

Tolerances: See [Table 6](#).

Table 6

Time Point (i)	Time (h)	Amount Dissolved (%)
1	1	14–34
2	3	35–55
3	8	60–80
4	24	NLT 80

The percentages of the labeled amount of carbamazepine ($C_{15}H_{12}N_2O$) dissolved at the times specified conform to [Dissolution <711>](#), [Acceptance Table 2](#).

Test 7: If the product complies with this test, the labeling indicates that it meets USP *Dissolution Test 7*.

Medium

For Tablets labeled to contain 100 or 200 mg: [Water](#); 900 mL, deaerated

For Tablets labeled to contain 400 mg: [Water](#); 1800 mL, deaerated

Apparatus 1: 100 rpm with sinker. [NOTE—A suitable 8-mesh basket sinker with cover may be used.]

For *Tablets* with a release hole, orient the hole facing downward in the basket.

Times

For Tablets labeled to contain 100 mg: 2, 4, 6, 12, and 24 h

For Tablets labeled to contain 200 or 400 mg: 2, 4, 6, and 24 h

Mobile phase: [Methanol](#), [water](#), [triethylamine](#), and [trifluoroacetic acid](#) (60: 40: 0.1: 0.1)

Standard solution: 0.22 mg/mL of [USP Carbamazepine RS](#) prepared as follows. Weigh a suitable amount of [USP Carbamazepine RS](#) in a suitable volumetric flask. Add [methanol](#) to 5% of the flask volume and sonicate to dissolve. Dilute with *Medium* to volume.

Sample solution: At the specified time points, withdraw a suitable volume of the solution under test. Pass through a suitable filter of 0.45- μm pore size, discarding an appropriate volume of filtrate so that a consistent result can be obtained.

Chromatographic system

(See [Chromatography \(621\)](#), [System Suitability](#).)

Mode: LC

Detector: UV 285 nm

Column: 4.6-mm \times 15-cm; 5- μm packing [L1](#)

Flow rate: 1 mL/min

Injection volume: 10 μL

Run time: NLT 2 times the retention time of carbamazepine

System suitability

Sample: *Standard solution*

Suitability requirements

Tailing factor: NMT 2.0

Relative standard deviation: NMT 5.0%

Analysis

Samples: *Standard solution* and *Sample solution*

Calculate the concentration (C_i) of carbamazepine ($\text{C}_{15}\text{H}_{12}\text{N}_2\text{O}$) in the sample withdrawn from the vessel at each time point (i):

$$\text{Result}_i = (r_U/r_S) \times C_S$$

r_U = peak response of carbamazepine from the *Sample solution*

r_S = peak response of carbamazepine from the *Standard solution*

C_S = concentration of [USP Carbamazepine RS](#) in the *Standard solution* (mg/mL)

Calculate the percentage of the labeled amount of carbamazepine ($\text{C}_{15}\text{H}_{12}\text{N}_2\text{O}$) dissolved at each time point (i):

$$\text{Result}_1 = C_1 \times V \times (1/L) \times 100$$

$$\text{Result}_2 = \{[C_2 \times (V - V_S)] + (C_1 \times V_S)\} \times (1/L) \times 100$$

$$\text{Result}_3 = \{[C_3 \times [V - (2 \times V_S)]] + [(C_2 + C_1) \times V_S]\} \times (1/L) \times 100$$

$$\text{Result}_4 = \{[C_4 \times [V - (3 \times V_S)]] + [(C_3 + C_2 + C_1) \times V_S]\} \times (1/L) \times 100$$

$$\text{Result}_5 = \{[C_5 \times [V - (4 \times V_S)]] + [(C_4 + C_3 + C_2 + C_1) \times V_S]\} \times (1/L) \times 100$$

C_i = concentration of carbamazepine in the portion of the sample withdrawn at time point i (mg/mL)

V = volume of *Medium*, 900 or 1800 mL

L = label claim (mg/Tablet)

V_S = volume of the *Sample solution* withdrawn at each time point from the *Medium* (mL)

Tolerances: See [Table 7](#) and [Table 8](#).

Table 7

Time Point (i)	Time (h)	Amount Dissolved (for Tablets that contain 100 mg of carbamazepine) (%)
1	2	NMT 20
2	4	20–40
3	6	40–60
4	12	65–85
5	24	NLT 80

Table 8

Time Point (i)	Time (h)	Amount Dissolved (for Tablets that contain 200 mg of carbamazepine) (%)	Amount Dissolved (for Tablets that contain 400 mg of carbamazepine) (%)
1	2	NMT 30	NMT 20
2	4	35–55	25–45
3	6	55–75	45–65
4	24	NLT 80	NLT 80

The percentages of the labeled amount of carbamazepine ($C_{15}H_{12}N_2O$) dissolved at the times specified conform to [Dissolution \(711\)](#), [Acceptance Table 2](#).

▲ Test 9: If the product complies with this test, the labeling indicates that it meets USP *Dissolution Test 9*.

Medium

For Tablets labeled to contain 100 or 200 mg: [Water](#); 900 mL, deaerated

For Tablets labeled to contain 400 mg: [Water](#); 1800 mL, deaerated

Apparatus 1: 100 rpm, with sinkers. [NOTE—Suitable sinkers are available from www.universallab.co.in as catalog number UL00072 for Tablets labeled to contain 100 mg, catalog number UL/SP/0503 for Tablets labeled to contain 200 mg, and catalog number UL/SP/0504 for Tablets labeled to contain 400 mg.]

For Tablets with a release hole, orient the hole facing downward in the basket.

Times: 2, 6, 10, and 20 h

Standard stock solution: 0.45 mg/mL of [USP Carbamazepine RS](#) in [methanol](#). Sonicate to dissolve, if necessary.

Standard solution: 0.011 mg/mL of [USP Carbamazepine RS](#) from the *Standard stock solution* in *Medium*

Sample stock solution: At the specified time points, withdraw a suitable volume of the solution under test. Pass through a suitable filter of 0.45- μ m pore size, discarding an appropriate volume of

filtrate so that a consistent result can be obtained. Replace the portion removed from the solution under test with the same volume of *Medium*.

Sample solution

For Tablets labeled to contain 100 mg: Dilute 2.0 mL of the *Sample stock solution* with *Medium* to 20 mL.

For Tablets labeled to contain 200 or 400 mg: Dilute 1.0 mL of the *Sample stock solution* with *Medium* to 20 mL.

Instrumental conditions

(See [Ultraviolet-Visible Spectroscopy \(857\)](#).)

Mode: UV

Analytical wavelength: 284 nm

Blank: *Medium*

Analysis

Samples: *Standard solution* and *Sample solution*

Calculate the concentration (C_i) of carbamazepine ($C_{15}H_{12}N_2O$) in the sample withdrawn from the vessel at each time point (i):

$$\text{Result}_i = (A_U/A_S) \times C_S \times D$$

A_U = absorbance of the *Sample solution* at time point i

A_S = absorbance of the *Standard solution*

C_S = concentration of [USP Carbamazepine RS](#) in the *Standard solution* (mg/mL)

D = dilution factor for the *Sample solution*

Calculate the percentage of the labeled amount of carbamazepine ($C_{15}H_{12}N_2O$) dissolved at each time point (i):

$$\text{Result}_1 = C_1 \times V \times (1/L) \times 100$$

$$\text{Result}_2 = [(C_2 \times V) + (C_1 \times V_S)] \times (1/L) \times 100$$

$$\text{Result}_3 = \{(C_3 \times V) + [(C_2 + C_1) \times V_S]\} \times (1/L) \times 100$$

$$\text{Result}_4 = \{(C_4 \times V) + [(C_3 + C_2 + C_1) \times V_S]\} \times (1/L) \times 100$$

C_i = concentration of carbamazepine in the portion of the sample withdrawn at time point i (mg/mL)

V = volume of the *Medium*, 900 or 1800 mL

L = label claim (mg/Tablet)

V_S = volume of the *Sample solution* withdrawn at each time point and replaced with *Medium* (mL)

Tolerances: See [Table 10](#).

Table 10

Time Point (i)	Time (h)	Amount Dissolved (%)
1	2	NMT 20

Time Point (i)	Time (h)	Amount Dissolved (%)
2	6	40–60
3	10	59–79
4	20	NLT 80

The percentages of the labeled amount of carbamazepine ($C_{15}H_{12}N_2O$) dissolved at the times specified conform to *Dissolution* (711), *Acceptance Table 2*. ▲ (TBD)

- **UNIFORMITY OF DOSAGE UNITS** (905): Meet the requirements

IMPURITIES

● ORGANIC IMPURITIES: PROCEDURE 1

Mobile phase: [Methanol](#), [methylene chloride](#), and [water](#) (450:45:600)

System suitability solution: 60 µg/mL of phenytoin and 20 µg/mL of [USP Carbamazepine RS](#) in [methanol](#)

Standard solution: 4 µg/mL of [USP Carbamazepine RS](#) in [methanol](#)

Sample solution: Use *Sample stock solution A* from the Assay.

Chromatographic system and System suitability: Proceed as directed in the Assay.

Analysis

Samples: *Standard solution* and *Sample solution*

Calculate the percentage of each impurity in the portion of Tablets taken:

$$\text{Result} = (r_U/r_S) \times (C_S/C_U) \times 100$$

r_U = peak response of each impurity from the *Sample solution*

r_S = peak response of carbamazepine from the *Standard solution*

C_S = concentration of [USP Carbamazepine RS](#) in the *Standard solution* (mg/mL)

C_U = nominal concentration of carbamazepine in the *Sample solution* (mg/mL)

Acceptance criteria

Any individual unspecified degradation product: NMT 0.2%

● ORGANIC IMPURITIES: PROCEDURE 2

Mobile phase: [Methanol](#), [acetonitrile](#), and [water](#) (35:15:50)

System suitability solution: 12.5 µg/mL of iminostilbene and 5.0 µg/mL of [USP Carbamazepine RS](#) in [methanol](#)

Standard solution: 4 µg/mL of [USP Carbamazepine RS](#) in [methanol](#)

Sample solution: Use *Sample stock solution A* from the Assay.

Chromatographic system: Proceed as directed in the Assay.

System suitability

Sample: *System suitability solution*

[NOTE—The relative retention times for carbamazepine and iminostilbene are about 0.3 and 1.0, respectively.]

Suitability requirements

Resolution: NLT 10.0 between carbamazepine and iminostilbene

Relative standard deviation: NMT 2.0%

Analysis

Samples: *Standard solution* and *Sample solution*

Calculate the percentage of each impurity in the portion of Tablets taken:

$$\text{Result} = (r_U/r_S) \times (C_S/C_U) \times 100$$

r_U = peak response of each impurity from the *Sample solution*

r_S = peak response of carbamazepine from the *Standard solution*

C_S = concentration of [USP Carbamazepine RS](#) in the *Standard solution* (mg/mL)

C_U = nominal concentration of carbamazepine in the *Sample solution* (mg/mL)

Acceptance criteria

Any individual unspecified degradation product: NMT 0.2%

Total impurities: NMT 0.5% for all impurities from *Procedure 1* and *Procedure 2*.

ADDITIONAL REQUIREMENTS

- **PACKAGING AND STORAGE:** Preserve in tight containers, and store at controlled room temperature.
- **LABELING:** The labeling states the *Dissolution* test used only if *Test 1* is not used.
- **USP REFERENCE STANDARDS** (11).

[USP Carbamazepine RS](#)

¹ A suitable sinker is available as catalog number SI-0103A000100 from www.labcx.com.

Page Information:

Not Applicable

Current DocID:

© The United States Pharmacopeial Convention *All Rights Reserved*.